

MONUMENT GUIDE



If your destiny was not to live and work in a big city or a foreign land, it was just as important and admirable ... to serve the place where you found yourself and felt yourself fulfilled, no matter how small or obscure that place might seem to the rest of the world.

-Kurt Vonnegut

How will you remember them?

Monument Types

Upright Monuments

Upright monuments consist of the die (or tablet) and the base. The die is the top part of the monument that sits on the base. The tops are usually serpentine, oval or straight, however other styles and custom shapes are also available. The base is the lower part of the monument and generally has a polished top and rock finished sides.

Benches

Benches are an ideal choice in areas where people pass or gather. They are an excellent option in areas such as parks and other public places where typical monuments may not be suitable.

Slant

Similar to an upright monument but generally shorter and with the tablet cut with a slanted face. Basic Monument Styles. They may have one or two names and are generally 1 foot 2 inches high (or higher in increments of 2") and 10" or 12" wide.

Mausoleums

Mausoleums are large monuments that actually enshroud the body. They can be quite elaborate and often shelter a whole family.

Bevel or Hickey Markers

Bevel markers have a beveled or slanted face where the back of the stone is a few inches higher than the front. They are generally 8" high and have an 1 1/2" drop back to the front.

Grass or Flush Markers

A grass or flush marker is a stone that sits flush with the ground. These markers are generally 24" x 12", but may be larger or smaller. This is the most common style for veteran's markers. Flush markers are also used to mark individual graves when there is a large upright stone on a family plot.

Bronze Markers

An individually cast bronze plate that is usually mounted upon a flush 24" x 12" stone. Bronze markers may also be mounted to other types of monuments and commonly found on mausoleums. These markers are extremely durable and the letters and symbols are raised up from the background.

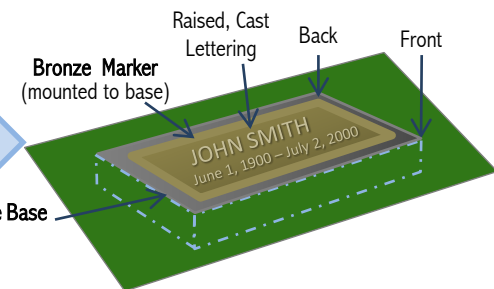
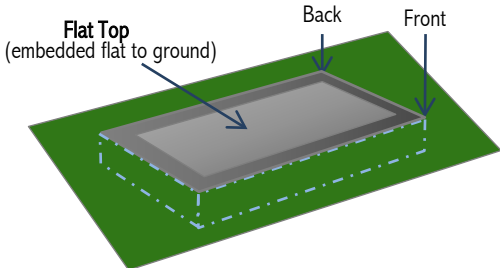
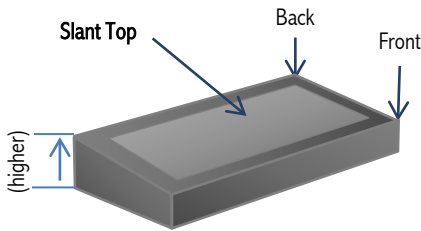
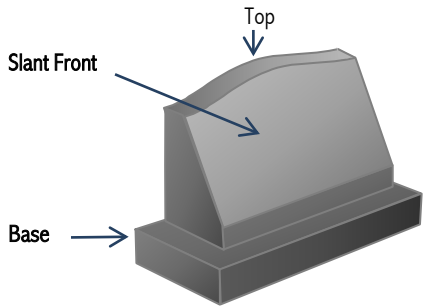
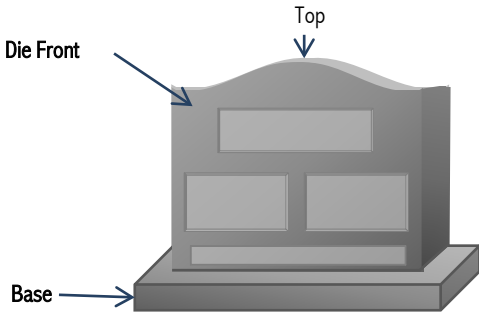
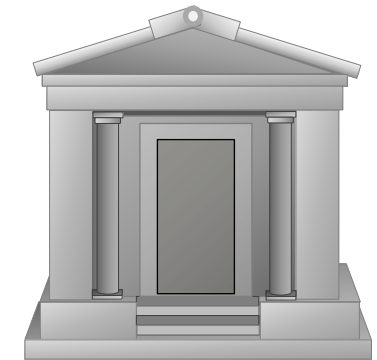

Basic Elements of a Monument

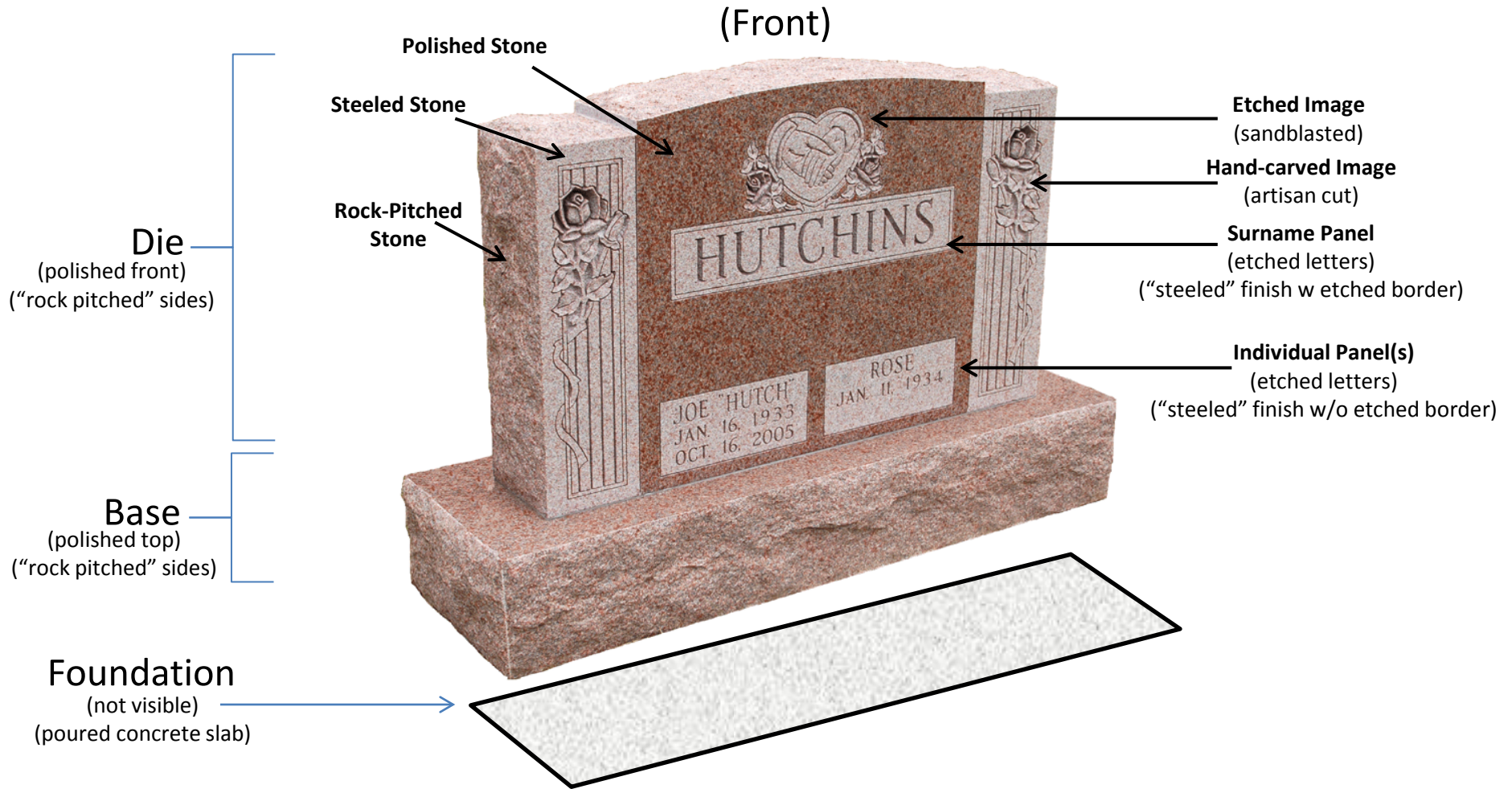

Note: Ornamentation or polishing may also be applied to the back of the stone.

Upright Monument Shape Guide

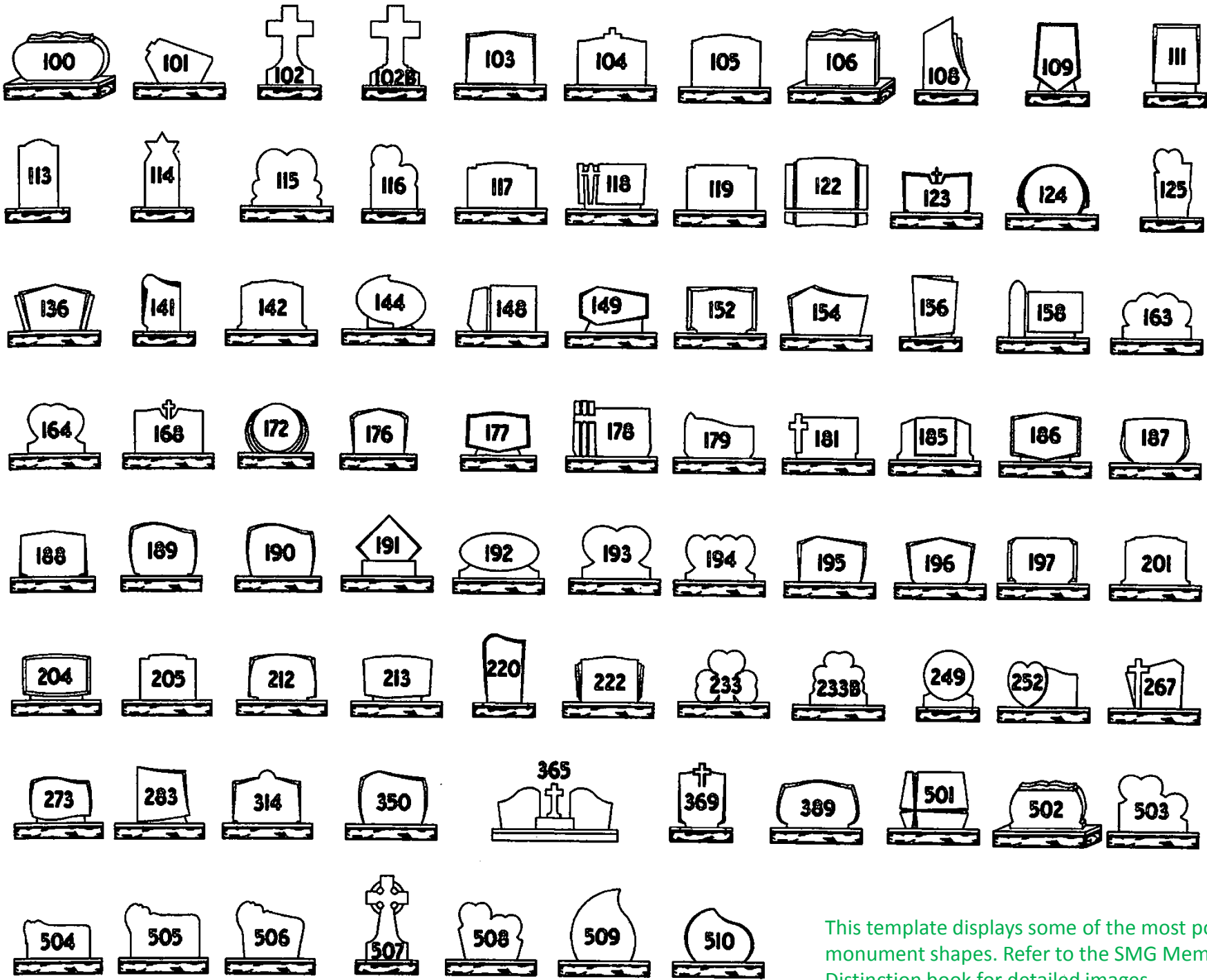

This template displays some of the most popular monument shapes. Refer to the SMG Memorials of Distinction book for detailed images.



Stone Material Guide

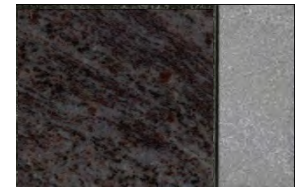
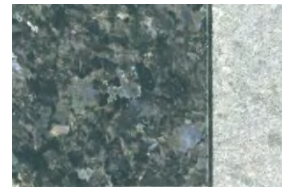
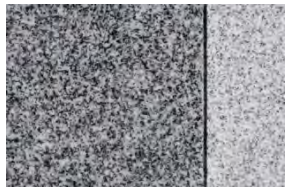

Barre Gray is a true granite that is mined in Barre, Vermont. Known as "Barre Gray" it is the most popular stone for monuments and is world-renown for being both durable and affordable.

COMMERCIAL NAME: Barre Gray
COUNTRY: USA
COLOR: Gray to Black with irregular light gray specks.
WATER ABSORPTION: 0.21-0.30%
ALSO CALLED: Barre Gray, Barre Medium

This granite has a light to dark brown grain pattern over a blackish brown background. You'll find it with and without white specks. This granite is a good alternative to Dakota or Canadian Mahogany.

COMMERCIAL NAME: Tan Brown
COUNTRY: India - Andhra Pradesh
COLOR: Black-brown
WATER ABSORPTION: 0.11%-0.15%
ALSO CALLED: Chestnut Brown, Chestnut Brown Tan, Copper Antique

Blue Pearl is coarse grained and has a dark blue grayish background - the glimmering light blue to dark green crystals reflect light. This stone has a very large grain.

COMMERCIAL NAME: Blue Pearl
COUNTRY: Norway
COLOR: Blue/ Blue-gray
WATER ABSORPTION: 0.03-0.15%
ALSO CALLED: Blue Labrador Hell, Blue Pearl Granite, GA 601, Labrador Azzurro, Labrador Blau, Labrador Bleu, Labrador Blue, Labrador Chiaro, Labrador Claro, Labrador Hell, Ljus Labrador, Perla Azzurro, Stalaker

Swirls of variegated light and dark granite in blue/gray with some red (garnet) accents. The colors and shades vary so it's best to view your actual stone.

COMMERCIAL NAME: Bahama Blue
COUNTRY: India
COLOR: blue/gray with accents
WATER ABSORPTION: 0.15%-0.25%
ALSO CALLED: Coral Blue, Vizag Blue



Stone Material Guide

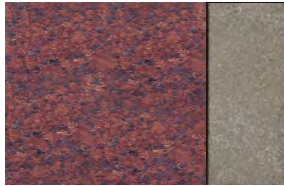
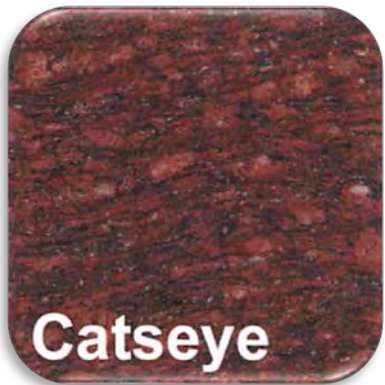
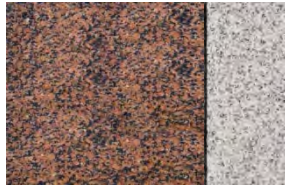
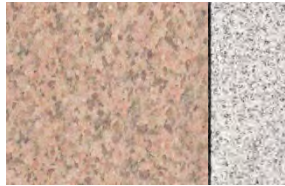
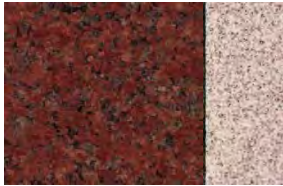

A deep red stone with medium sized crystal patterns.

COMMERCIAL NAME: Indian Red
COUNTRY: India - Karnataka
COLOR: Dark Red with irregular dark gray specks.
WATER ABSORPTION: 0.1-0.15%
ALSO CALLED: IMPERIAL RED, NEW IMPERIAL; RUBY RED is similar and from the same area.

Light, pale pink with uniform mild patterning, this granite forms a gentle backdrop with good definition for contrasted etching.

COMMERCIAL NAME: Salisbury Pink
COUNTRY: USA - North Carolina
COLOR: Light, pale pink with uniform mild patterning.
WATER ABSORPTION: 0.20-0.30%
ALSO CALLED: ST. ALBANS PINK

A Pinkish-Red field of granite sprinkled with black and white diamond flecks. Fine grained and very hard. When steeled it produces a lovely soft pink hue. Similar stones available from Canada and North Carolina.

COMMERCIAL NAME: Canadian Pink
COUNTRY: Canada, India - Kandla
COLOR: Pink with irregular gray specks
WATER ABSORPTION: 0.1-0.15%
ALSO CALLED: INDIA PINK, ROSY PINK

This is red brown granite having dark brown base with swirling patterns of large dark red grains.

COMMERCIAL NAME: Cat's Eye Granite
COUNTRY: India
COLOR: Reddish pink with black lines
WATER ABSORPTION: 0.20% -0.30%



Stone Material Guide

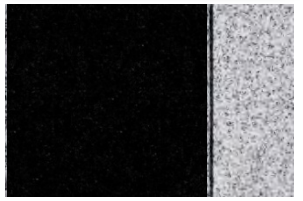

“Supreme” or “Absolute” Black granite is a true black stone quarried in South Africa. It is an extremely dense, fine grained natural stone which absorbs very little moisture and provides excellent contrast for engraving. The darker the stone and the finer the texture, the higher the quality and the higher the price.

COMMERCIAL NAME: Belfast Black
COUNTRY: South Africa
COLOR: Black
WATER ABSORPTION: 0.05% and 0.1%
ALSO CALLED: Absolute Black Granite, Afrika Schwarz, Negro Belfast, Nero Assoluto, Dunkel, SSY, SSY Granit

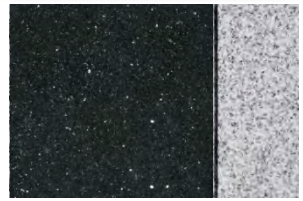

Goldstar has a dark black background with many sparkling bright crystals. It twinkles as the stone is viewed from different angles in various lights. The brightness of these crystals is visible on a polished surface only.

COMMERCIAL NAME: Black Galaxy
COUNTRY: India- Andhra Pradesh
COLOR: Black with golden specks.
WATER ABSORPTION: 0.04%-0.15%
ALSO CALLED: Black Armetista, Black Amethyst, Black and Gold, Black Gold Sands, GA902, Galaxi Black, Galaxy Black, Galaxy Gold, Galaxy Star, Nero Ametista, Nero Galassia, Nero Galaxy, Nero Star Galaxi, Nero Star Galaxy, Star Galaxi, Star Galaxy Black, Star Galaxy, WG 203

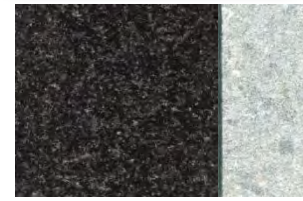

Black Impala, is a dark gray natural stone quarried in South Africa. It has a textured pattern but is still very good for engraving contrast.

COMMERCIAL NAME: Impala Black
COUNTRY: SOUTH AFRICA - The Bosspruit region, Rustenburg, INDIA
COLOR: Dark Gray
WATER ABSORPTION: 0.05%-0.15%
ALSO CALLED: Afrika Schwarz, Eagle Black, Impala Black, Impala Gabbro, Impala KM, Impala Nero, Impala Schwarz, Jasberg, Marikana Black, Negro Rustenburg, Nero Afrika, Nero Impala Africa, Nero Rustenberg, Noir Afrique, Preto SK, Rustenberg Gray, Rustenberg Impala

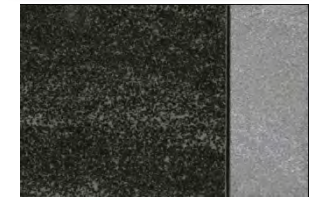

Ebony Mist, also called Virginia Mist or “Wavy Black” is a dark gray to black fine grained natural stone with tiny flecks of light gray. The subtle pattern of the stone perfectly compliments engravings of natural scenery.

COMMERCIAL NAME: Virginia Mist
COUNTRY: USA – Virginia, Pennsylvania
 India - Andhra Pradesh, Karnataka, Tamil Nadu
COLOR: Dark Gray to Black with irregular light gray specks.
WATER ABSORPTION: 0.05%-0.15%
ALSO CALLED: Black India, India Black, Indisch-Schwartz, Indisch Black, Nero India



Stone Material Guide

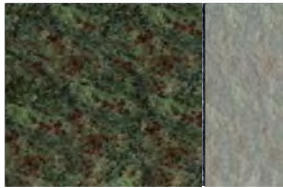

A busy granite consisting of a blending of various shades of green and black and some burgundy speckling.

COMMERCIAL NAME: Tropical Green

COUNTRY: India - Kerala

COLOR: Green with green-black and red spots.

WATER ABSORPTION: 0.20-0.30%

ALSO CALLED: Kerala Green, Verde

Tropical G, Verde Imperiale, Verde Kerala

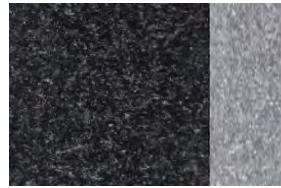

The most popular green granite; a consistent dark green, fine grained granite. Very Rare. Beautiful green pattern with hints of browns and black. **Subject to availability.**

COMMERCIAL NAME: Evergreen

COUNTRY: USA

COLOR: Light gray-green, dark gray-green. Brown tone.

WATER ABSORPTION: 0.10-0.40%

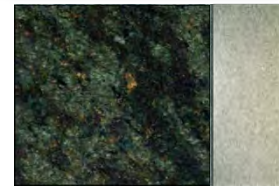

A consistent green granite with soft gray and burgundy speckling.

COMMERCIAL NAME: Green Galaxy

COUNTRY: India

COLOR: green/green-gray

WATER ABSORPTION: 0.08%

ALSO CALLED: Green Galaxy, Ceeweed Green, Pine Green, Sea Weed Green, Seaweed Green, Seawwed Green, Sewed Green, Titanic Green

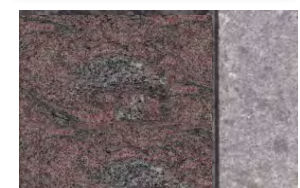
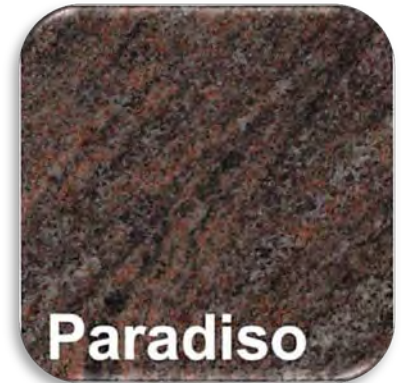

A swirling pink and gray gneiss pattern. This stone forms dramatic color patterns.

COMMERCIAL NAME: Paradiso Classico

COUNTRY: India -Tamil Nadu

COLOR: Rose-violet, light gray with black waves

WATER ABSORPTION: 0.20-0.30%

ALSO CALLED: PARADISO DARK, variety: PARADISO LIGHT, PARADISO CHIARO



Popular Lettering Fonts

ROMAN MODIFIED
ROMAN CONDENSED
VERMARCO
NELSON VERMARCO
GOVERNMENT
COMMON GOTHIC
SPLAYED GOTHIC
HELVETICA MEDIUM
ROUND RAISED
NELSON ROMAN MODIFIED
KORINNA
GOUDY
GOUDY BOLD
CLASSIC ROMAN
SPECIAL ROMAN II
MODERN CLASSIC ROMAN
OUTLINED ROMAN
OUTLINE VERMARCO
OUTLINE NELSON VERMARCO
POLISHED EDGE ROMAN

SHADOW EDGE ROMAN
POLISHED EDGE WIDE
Times Roman
Helvetica Regular
Universal
Garamond Bold
Latin
Nelson Times Roman
Futura Medium
Optima Medium
Script
Zapf Chauncery
Behm Script
Murray Hill Bold
Roman Modified Script
Round Serif
Old English
Chapel
UNCIAL GOTHIC
Irish

- Minimum letter size for most fonts/stone types is 1".
- Patterned stones may need a box called a "panel" for contrast.
- Smaller letters and additional fonts may be achievable with laser engraving.

Carving & Etching Techniques



Flat Carving

Flat carving is a technique where an outline of a design is carved using a template and sandblasting into the face of the monument.



Etching

Etching is a method of carving the polished surface of dark granites. Etching can be done by laser or by hand.



Shape Carving

Shape carving is a technique that is generally used for flowers. The outline of the design is shaped to look three dimensional.



Painted Etching

After etching or carving, an additional step of applying a colored enamel may be done to enhance the image.



Hand Carving

A skilled artisan hand cuts a detailed 3-D relief into the stone.



Sculpting

Full sculpting is the most labor intensive and requires the artisan to completely shape the stone.



Glassed Etching

A very new development: Molten glass is applied to the etching to form a very durable image with both exceptional contrast and permanence.

Lettering Techniques



TO HONOR THOSE WHO SERVED
FROM REAL COUNTY IN THE
MILITARY FORCES OF THE
UNITED STATES OF AMERICA
IN WAR AND PEACE AND IN
LOVING MEMORY OF THOSE
WHO GAVE THEIR LIVES IN
THAT SERVICE.



Sunken Lettering

Letters are carved deep into the stone by a sandblaster. This is usually done in a “steeled” panel for maximum contrast on patterned or dark stone. Minimum letter size is about one inch.



V-SUNK IN PANEL

Skin Cut Lettering (Frosted)

A dark polished stone of uniform pattern can be deeply etched to show the lighter color of the rough stone. Minimum letter size is about one-half inch.



Frosted Inlaid Lettering

The outline of the letters is first etched deeply then the interior of the letters is skin cut, creating maximum contrast. Minimum letter size of two inches.



FROSTED INLAID

Polished Outline Lettering

Similar to frosted outline, the outline is deep cut, then the panel is skin cut leaving the letters polished to show the stone’s natural pattern. Minimum letter size of two inches.



POLISHED INLAID

Raised Lettering

The most elaborate and costly of the lettering styles. Everything but the letter is deeply cut into the stone. Often the letters are rounded for an antique look. Minimum letter size of two inches.



POLISHED RAISED

Laser Etched Lettering

Laser etching may be used on dark stone to engrave unique fonts, very small letters and large texts efficiently and at minimal cost. Minimum letter size about one quarter inch.

